

TYPICAL QS-1612 DEAL TRAY INSTALLATION

- 1) QUIKSERV DEAL TRAYS MUST BE INSTALLED LEVEL AND SQUARE TO WORK PROPERLY.
- 2) ANCHOR SCREWS, SILICONE OR CLIPS TO BE SUPPLIED BY CONTRACTOR.
- 3) CUT HOLE IN COUNTER TOP 14-1/2" x 10-1/2" SO DEAL TRAY FITS FLUSH TO COUNTER TOP. (SEE ROUGH OPENING SIZE BELOW)
- 4) DEAL TRAY CAN BE SILICONED, SCREW APPLIED OR THE USE OF STANDARD KITCHEN SINK CLIPS CAN BE USED TO SECURE DEAL TRAY.
- 5) SILICONE ALL EXTERIOR AND INTERIOR JOINTS.
- 6) ALL OTHER TYPE OF ANCHORING TO BE APPROVED BY CERTIFIED ENGINEER.

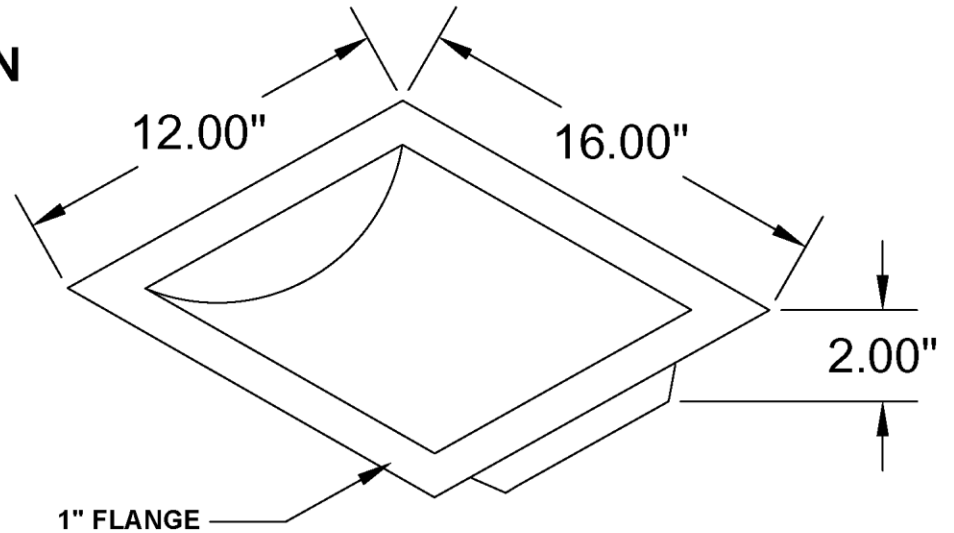

NOTE: THIS DRAWING EMBODIES A CONFIDENTIAL PROPRIETY DESIGN ORIGINATED AND OWNED BY QUIKSERV CORP., AND IS SUBMITTED UNDER A CONFIDENTIAL RELATIONSHIP. ALL PATENT, MANUFACTURING, SALE RIGHTS REGARDING THE SAME ARE RESERVED EXCEPT TO THE EXTENT RIGHTS ARE EXPRESSLY GRANTED TO OTHERS. THE RECIPIENT AGREES BY ACCEPTING THESE DRAWINGS NOT TO SUPPLY OR DISCLOSE ANY INFORMATION REGARDING THEM TO ANY UNAUTHORIZED PERSON.

Job Name:

Actual Dimension:
16" (W) X 12" (L)

Rough Opening:
14-1/2" (W) X 10-1/2" (L)

Represented by:
Interbank-Exchange, LLC
P.O. Box 632
Black Canyon City, AZ 85324

QS-1612 Deal Tray Installation Drawing

Drawing Name:
QS-1612 INSTALLATION

Scale:
N/A

Date:
12/26/2010

Drawn By:
BC

Rev.